

# **CITY THEATRICAL**

**NEW YORK • LONDON**

## **7400-5707 SHoW DMX Vero<sup>®</sup> Transceiver User's Manual**

Rev 2



© 2012 City Theatrical, Inc.

SHoW DMX Transceivers are covered by U.S. Patent # 7,432,803 and other patents pending.

**US HEADQUARTERS**  
475 BARELL AVENUE  
CARLSTADT, NEW JERSEY 07072  
TEL 800 230 9497 / 201 549 1160  
FAX 201 549 1161

[www.citytheatrical.com](http://www.citytheatrical.com)

**LONDON OFFICE**  
UNIT 1-3 WYVERN ESTATE, BEVERLEY WAY  
NEW MALDEN, SURREY KT3 4PH  
TEL +44 (0) 20 8949 5051  
FAX +44 (0) 20 7183 6061

<b>Radio Compliance Information .....</b>	<b>3</b>
Antennas.....	4
5792 SHoW DMX Neo Radio Module CE Declaration of Conformity.....	6
<b>System Compliance Information.....</b>	<b>7</b>
<b>Safety Notices, Ratings and Power Requirements.....</b>	<b>7</b>
<b>Introduction .....</b>	<b>8</b>
<b>Setting up the 7400-5707 SHoW DMX Vero Transceiver.....</b>	<b>9</b>
Installation .....	9
Warning.....	9
Important use notes.....	9
Grounding.....	9
Mounting Bracket .....	9
Surface Mounting .....	9
Mounting Orientation.....	10
Pipe Mounting .....	10
Cable or Conduit Entry.....	11
Mains Wire Installation and Termination.....	11
DMX512 Wire Termination .....	11
Installing the Cover .....	12
The 7400-5707 SHoW DMX Vero Transceiver Settings.....	13
Configuration .....	13
SHoW ID.....	14
Neo Mode Operation.....	14
Neo SHoW ID Tables .....	14
Neo Adaptive Mode Operation .....	16
Neo Adaptive SHoW ID Table .....	16
Adjustable Output Power.....	17
Limited Bandwidth Hopping .....	17
Limited Burst DMX Output.....	17
RDM Operation.....	17
Optional or Custom Antenna Accessories .....	19

## **Radio Compliance Information**

5792 SHoW DMX Neo Radio Transceiver  
 FCC ID: VU65792  
 IC ID: 7480A5792

### FCC Part 15

This equipment has been tested and found to comply with the limits for a Class B digital device, pursuant to part 15 of the FCC Rules. These limits are designed to provide reasonable protection against harmful interference in a residential installation. This equipment generates, uses and can radiate radio frequency energy and, if not installed and used in accordance with the instructions, may cause harmful interference to radio communications. However, there is no guarantee that interference will not occur in a particular installation.

If this equipment does cause harmful interference to radio or television reception, which can be determined by turning the equipment off and on, the user is encouraged to try to correct the interference by one or more of the following measures:

- Reorient or relocate the receiving antenna.
- Increase the separation between the equipment and receiver.
- Connect the equipment into an outlet on a circuit different from that to which the receiver is connected.
- Consult the dealer or an experienced radio/ TV technician for help.

### Radio Frequency Notifications

#### FCC Notifications

**RF Radiation** The Product is an intentional radiator of Radio Frequency (RF) energy. In order to limit RF exposure to personnel in the immediate area, the Product should be located and installed such that a separation of at least 20 centimeters is maintained between the Product's antenna and personnel in the vicinity of the device.

#### Modification Warning

Caution: changes or modifications to this equipment, not expressly approved by City Theatrical Inc. could void the user's authority to operate the equipment.

#### Industry Canada Notifications

This Class B digital apparatus complies with Canadian ICES-003. Operation is subject to the following two conditions: (1) this device may not cause interference, and (2) this device must accept any interference, including interference that may cause undesired operation of the device.

Cet appareil numérique de la classe B est conforme à la norme NMB-003 du Canada.

Product Installation and Configuration Guide © City Theatrical Inc. 2007

#### 5792 Approved Antenna

To reduce potential radio interference to other users, the antenna type and its gain should be so chosen that the equivalent isotropically radiated power (e.i.r.p.) is not more than that permitted for successful communication.

This device has been designed to operate with the antennas listed below. Antennas not included in this list or having a gain greater than 5 dB are strictly prohibited for use with this device. The required antenna impedance is 50 ohms.

City Theatrical Inc. declares that this product conforms to the specifications listed in this manual, following the provisions of the European R&TTE directive 1999/5/EC:

City Theatrical Inc. vakuuttaa täten että dieses produkt tyyppinen laite on direktiivin 1999/5/EY oleellisten vaatimusten ja sitä koskevien näiden direktiivien muiden ehtojen mukainen.

City Theatrical Inc. déclare que le produit est conforme aux conditions essentielles et aux dispositions relatives à la directive 1999/5/EC.

- EN 301 489-1, 301 489-17 General EMC requirements for Radio equipment.
- EN 60950 Safety
- EN 300 328 Technical requirements for Radio equipment.

**CAUTION**—This equipment is intended to be used in all EU and EFTA countries.

Outdoor use may be restricted to certain frequencies and/or may require a license for operation. Contact local Authority for procedure to follow.

**Note:** ESD precautions should be used when attaching or removing the antenna.

**Note:** Combinations of power levels and antennas resulting in a radiated power level of above 100 mW equivalent isotropic radiated power (EIRP) are considered as not compliant with the above mentioned directive and are not allowed for use within the European community and countries that have adopted the European R&TTE directive 1999/5/EC. For more details on legal combinations of power levels and antennas, contact City Theatrical Inc.

Do not use this product near water, for example, in a wet basement or near a swimming pool.

Avoid using this product during an electrical storm. There may be a remote risk of electric shock from lightning.

Product Installation and Configuration Guide © City Theatrical Inc. 2011

#### Q52 Regulatory information

##### Radio Frequency Notifications

**Belgique** Dans le cas d'une utilisation privée, à l'extérieur d'un bâtiment, au-dessus d'un espace public, aucun enregistrement n'est nécessaire pour une distance de moins de 300m. Pour une distance supérieure à 300m un enregistrement auprès de l'IBPT est requise. Pour une utilisation publique à l'extérieur de bâtiments, une licence de l'IBPT est requise. Pour les enregistrements et licences, veuillez contacter l'IBPT.

**France** 2.4 GHz Bande : les canaux 10, 11, 12, 13 (2457, 2462, 2467, et 2472 MHz respectivement) sont complètement libres d'utilisation en France (en utilisation intérieur). Pour ce qui est des autres canaux, ils peuvent être soumis à autorisation selon le département. L'utilisation en extérieur est soumise à autorisation préalable et très restreinte. Vous pouvez contacter l'Autorité de Régulation des Télécommunications (<http://www.art-telecom.fr>) pour de plus amples renseignements.

## Antennas

The model: 5792 can be configured with any one of the approved antennas listed below for fixed, point-to-point one server and one client configuration. When the model: 5792 is configured for point-to-multipoint one server and multiple clients' configuration (client's talk to server only one at a time), client's can use any of the approved antennas listed below and the server can use any of the approved antennas listed below with the exception of the 14dBi antenna.

#### 5792 FCC/IC Approved Antennas:

Manufacturer	Model	Type	Connector	Gain
Nearson	S151AH-2450S	Omni whip	SMA plug reverse polarity	5dBi
Nearson	S141AH-2450	Omni whip	SMA plug reverse polarity	2dBi
Nearson	S131AH-2450	Omni whip	SMA plug reverse polarity	2dBi
Nearson	DG102N-2.4/5.25	Omni whip, outdoor use	SMA plug reverse polarity via provided Antenna Cable	5dBi
Tekfun	F40-N	Omni whip, outdoor use	Male N	4.5dBi
Centurion	WCP2400- MMCX4	Omni whip	MMCX jack on 4" coax pigtail	2.5dBi
Maxrad	MP24008XFPT	Panel, outdoor use	SMA plug reverse polarity via provided Antenna Cable	8dBi
Maxrad	MYP24010PT	Yagi, outdoor use	SMA plug reverse polarity via provided Antenna Cable	10dBi
Maxrad	MYP24014PT	Yagi, outdoor use	SMA plug reverse polarity via provided Antenna Cable	14dBi

## 5792 CE Approved Antennas:

Manufacturer	Model	Type	Connector	Gain
Nearson	S151AH-2450S	Omni whip	SMA plug reverse polarity	5dBi
Nearson	S141AH-2450	Omni whip	SMA plug reverse polarity	2dBi
Nearson	S131AH-2450	Omni whip	SMA plug reverse polarity	2dBi
Nearson	DG102N-2.4/5.25	Omni whip, outdoor use	SMA plug reverse polarity via provided Antenna Cable	5dBi
Tekfun	F40-N	Omni whip, outdoor use	Male N	4.5dBi
Centurion	WCP2400- MMCX4	Omni whip	MMCX jack on 4" coax pigtail	2.5dBi

For installations governed by FCC and/or IC rules, any of the approved antennas listed above may be used with the SHoW DMX Vero Transceiver (please note the special installation requirements for use with the CTI # 5636 14 dBi Yagi Antenna).

Please note that some of the antennas listed are intended for indoor use only.

For use in locations governed by CE rules, some antenna restrictions apply. Antennas from the **5792 CE Approved Antennas** meet all requirements. Contact City Theatrical for details.

ETSI power settings for all 5792 SHoW DMX Neo Radio module equipped products, including the SHoW DMX Vero Transceiver, are based on use with the CTI 5630 5 dBi Omni Antenna. ETSI power and range will vary with the antenna used. Contact your dealer or City Theatrical for more information. CE Mark Conformity

5792 SHoW DMX Neo Radio Module CE Declaration of Conformity



**EC Certificate of Conformity**

**Products covered by this Certificate**

SHoW DMX Neo™

5792 Radio Module

**Standards Applied**

EN 301-489-1 V1.8.1 (2008-04)  
EN 301 489-17 V2.1.1 (2009-05)  
ETSI EN 300 328 v1.7.1 (2006-10)

**Product Conforms to CE Marking Directive 93/68/EEC**

Date of Issue: August 15, 2011

Year CE Marking First Affixed: 2011

---

Lauren E. Dunn, Head of Engineering

US HEADQUARTERS  
475 BARELL AVENUE  
CARLSTADT, NEW JERSEY 07072  
TEL 800 230 9497 / 201 549 1160  
FAX 201 549 1161

[www.citytheatrical.com](http://www.citytheatrical.com)

LONDON OFFICE  
UNIT 1-3 WYVERN ESTATE, BEVERLEY WAY  
NEW MALDEN, SURREY KT3 4PH  
TEL +44 (0) 20 8949 5051  
FAX +44 (0) 20 7183 6061

## **System Compliance Information**



The 7400-5707 SHoW DMX Vero Net Transceiver is ETL Listed,  
Conforms to UL 508A

**Intertek**



The 7400-5707 SHoW DMX Vero Net Transceiver is CE Certified  
Standards Applied:

EN 55203-1: 2009

EN 55203-2: 2009

EN 301 489-1 V1.8.1

EN 301 489-3 V1.4.1

EN 60950-1:2006 / A1:2010

FCC Rules, Part 15, Subpart B, Sections 15.107 and 15.109

Products Conform to CE Marking Directive 93/68/EEC

All SHoW DMX Neo models are RoHS compliant

### **Safety Notices, Ratings and Power Requirements**

Please read this entire manual before using your new equipment. Please keep the manual in a safe place so you can refer to it in the future as required.

The SHoW DMX Neo System is intended for use only by qualified professionals. Connection, installation and hanging of this equipment must be performed in accordance with all pertinent local, regional and national safety codes and regulations.

The 7400-5707 SHoW DMX Vero Transceiver is intended for indoor or outdoor use.

The unit enclosure is rated NEMA 4 / IP66.

Rated operating voltage; 100-240VAC 50/60 Hz, 1A max.

This device must be provided with a 20A branch circuit breaker or equivalent suitable external disconnecting device.

Maximum operating temperature: 0°C - 40°C.

Warning: The 7400-5707 SHoW DMX Vero Net Transceiver must be mounted exclusively in an upright mounting position with the cable entries on the bottom and antenna connector on the top as shown in the Installation guide. See the Installation Guide in this document for details.

**RF Exposure:** The antenna(s) used for this transmitter must be installed to provide a separation distance of at least 20cm from all persons and must not be collocated or operating in conjunction with any other antenna or transmitter.

## **Introduction**

Thank you for using City Theatrical's 7400-5707 SHoW DMX Vero Transceiver.

The 7400-5707 SHoW DMX Vero Transceiver features include:

- NEMA 4 /IP 66 rated enclosure
- Transceiver, fully configurable for Transmit or Receive
- One model, FCC, IC and CE Certified
- New DMX synchronized hopping structure with increased interference immunity, reduced interference generation and extremely low latency
- Selectable true Adaptive Spread Spectrum Frequency Hopping (ASSFH) in Neo Modes

Two Operating Modes:

### Neo Mode

- Fully configurable using RDM commands from an external RDM controller or the host.
- Replace missing packets with previously received data if any are lost
- 7mS typical latency
- Selectable Output power (1-72mW ETSI)
- Selectable Bandwidth
- Selectable Burst Length (when used with full frame sources)
- Allows for shortened frame data (less than 512 bytes from source)
- Enhanced RDM Proxy performance

### Neo-Adaptive Mode

- Fully configurable using RDM commands from an external RDM controller or the host.
- Replace missing packets with previously received data if any are lost
- 7mS typical latency
- Adaptive Hopping
- Selectable Output power (1-72mW ETSI)
- Allows for shortened frame data (less than 512 bytes from source)

Every effort has been made to anticipate your questions in this manual, but if you have any questions that are not answered here, or you want to discuss a special application, please feel free to contact us directly at City Theatrical.



## **Setting up the 7400-5707 SHoW DMX Vero Transceiver**

### **Installation**

Install the SHoW DMX Vero Transceiver in a suitable location, following the instructions below. When selecting a mounting location, note that for best results the antennas in your system must be within sight of each other.

### **Warning**

To avoid electric shock, do not energize any circuits before all internal and external electrical and mechanical clearances are checked to assure that all assembled equipment functions safely and properly.

### **Important use notes**

This unit must be used with voltages below 600V

This unit must be installed in accordance with the National Electrical Code, ANSI/NFPA 70, where the ambient temperature does not exceed 40°C (104°F) maximum.

### **Grounding**

This enclosure has been provided with a ground bond jumper for ground connection between the back box and the cover. This jumper must be installed as shown in the drawing below, using the provided hardware.

### **Mounting Bracket**

The provided mounting Bracket Base can be mounted on a surface or a vertical pipe. For surface mounting, the Bracket base is provided with slots and holes suitable for #10 / M4 screws or similar fasteners.

### **Surface Mounting**

Mount the Mounting Bracket Base in the desired location using four x #10 / M4 screws (by others, as above).

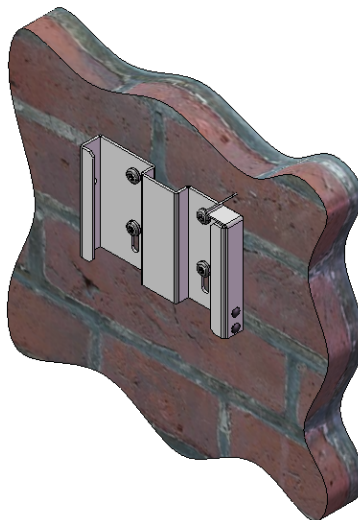

Slide the mating Mounting Bracket (attached to the Unit) into the Mounting Bracket Base until the locking clip engages, and install the provided 8-18 x .500" SS Thread Forming Torx Button Head Security Screw in the hole on the left side of the Bracket assembly.

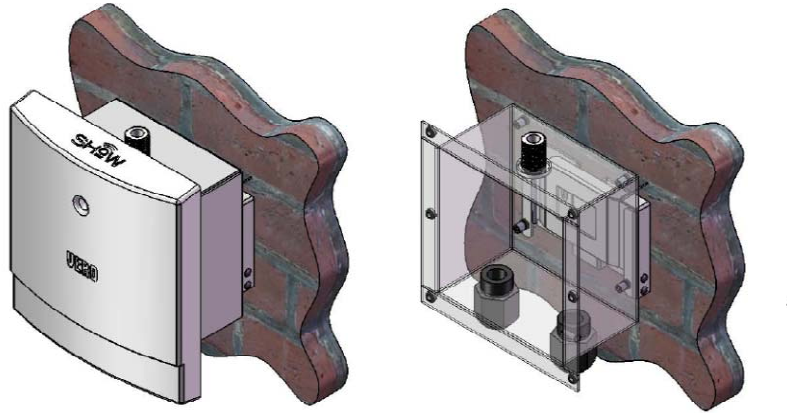

### Mounting Orientation

The 7400-5707 SHoW DMX Vero Transceiver must be mounted exclusively in an upright mounting position with the cable entries on the bottom and antenna connector on the top as shown in the drawing above.

### Pipe Mounting

The SHoW DMX Vero can also be mounted on a pipe. Attach the Mounting Bracket Base to a pipe using a stainless steel hose clamp as shown:

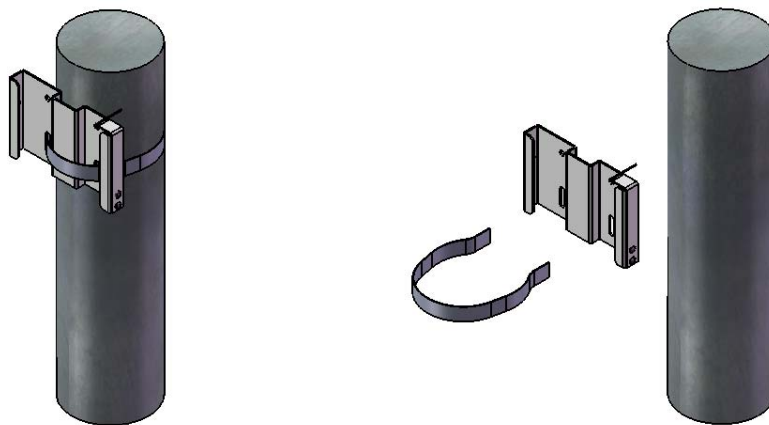

Slide the mating Mounting Bracket (attached to the Unit) into the Mounting Bracket Base until the locking clip engages, and install the retaining Screw.

### Cable or Conduit Entry

The unit enclosure is provided with ½" NPT entry holes fitted with liquid-tight cable grips for use with outdoor use cables (by installer) for power and DMX connection. The recommended torque for these cable grips is as follows:

Locking Nut	40-45 inch pounds
Sealing Nut	50-55 inch pounds

If outdoor use conduit is used instead, it is recommended that the conduit be sealed after installation to prevent moisture entry, including free air exchange, in order to minimize the chance of condensation buildup.

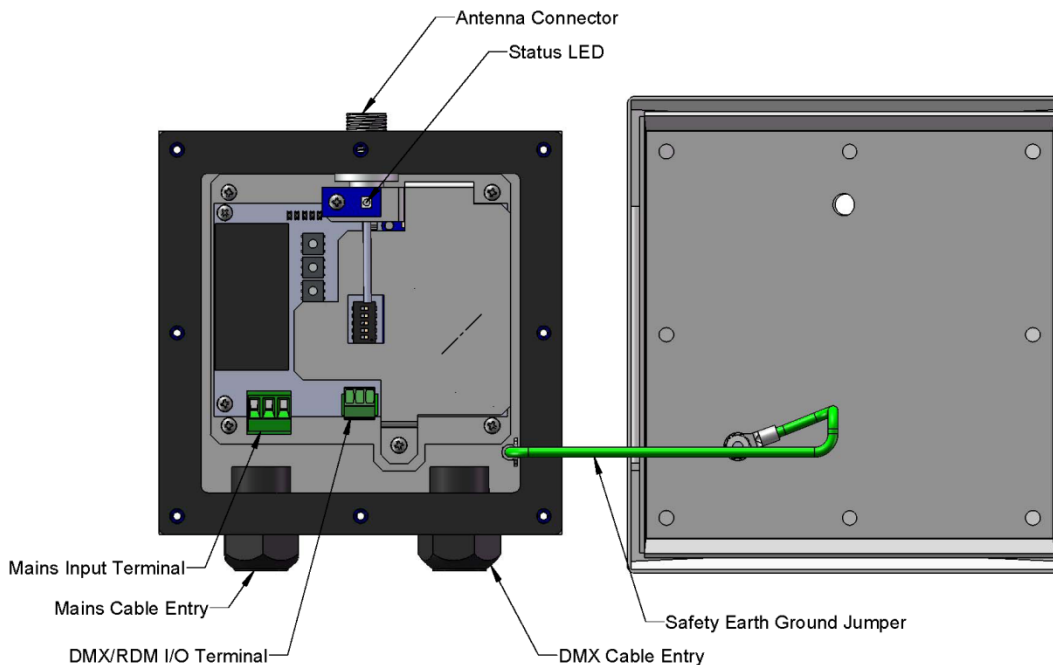

### Mains Wire Installation and Termination

Install the mains cable or conduit in the entry provided as shown in the drawing below. A liquid tight cable grip is provided for use with suitable outdoor rated cable with diameter range of .170"/4,3mm - .450"/11,4mm.

When cable is used, strip outer jacket 6"/150mm.

The mains connection is a 3 pos. plug/socket type terminal block which may be disconnected for ease of assembly. Strip insulation from individual conductors .25"/7mm and terminate in the provided screw terminal socket (see illustration above) Mains terminations are as shown and are marked on the unit.

### DMX512 Wire Termination

The SHoW DMX Vero Net Transceiver is provided with a PCBA mount terminal block for DMX connection (see illustration above). DMX Input / Output connections are as shown and are marked on the unit.

**Installing the Cover**

The 7400-5707 SHoW DMX Vero Transceiver has a two part cover, with the outer plastic cover connected to the inner metal cover with a hinge. Install the metal inner cover using the eight provided 6- 32 x .375" SS Truss Head Machine Screws. Hand install these screws until the screw threads are fully engaged with the mating PEM Nut, then tighten to 4 inch pounds.

The outer cover is then closed and secured with the provided 8-18 x .500" SS Thread Forming Torx Button Head Security Screw, installed in the provided hole on the left side of the cover assembly.

## The 7400-5707 SHoW DMX Vero Transceiver Settings

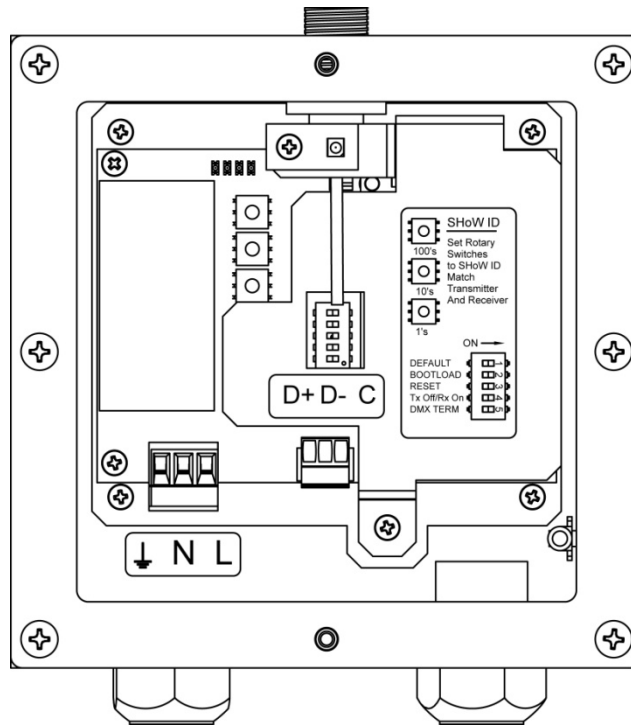

Internal Markings

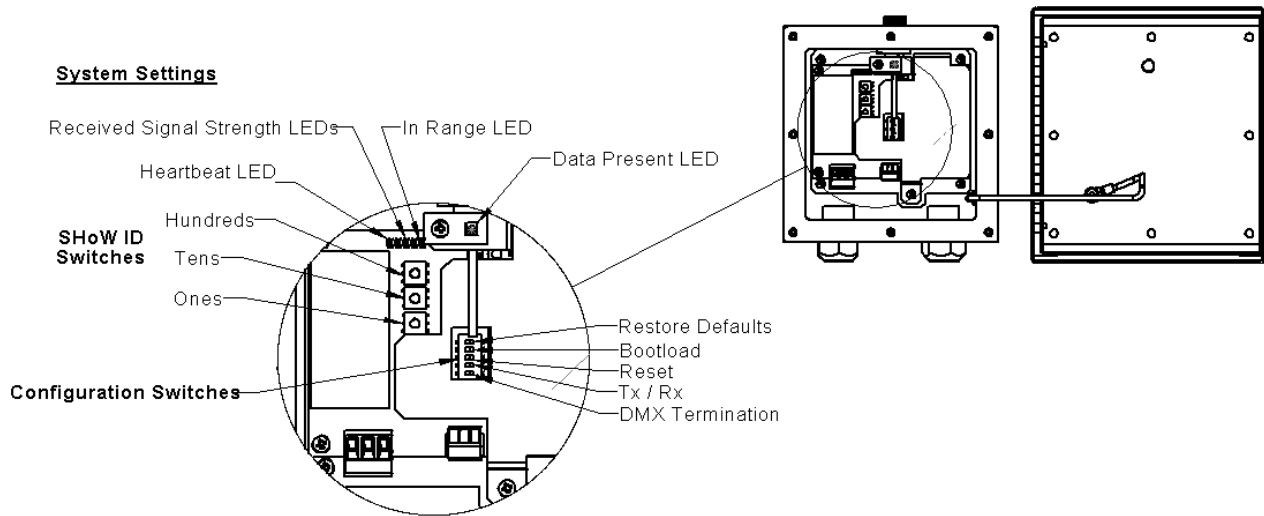

### Configuration

You can configure the Vero Transceiver's basic operating settings using the System Settings (SHoW ID and Configuration) switches shown in the detail above.

Configuration switches:

P5, DMX Term: DMX512 termination On or Off. Turn On for end-of-line DMX512 connection.

P4, Rx/Tx: Receiver (Rx) On, or Transmitter (Tx) Off. Selects Receiver or Transmitter operation

P3, Reset: On or Off. Switch On to hold in Reset

P2 Bootloader: On or Off. Sets the unit to Bootloader mode to upload and install radio firmware upgrades from a connected SHoW DMX Neo Transceiver or Receiver.

P1 Default: On or Off. To restore the system to factory default settings:

1. Set P1 Default to On
2. Wait for Data Present LED to blink rapidly
3. Switch P1 to Off

## SHoW ID

Like the original SHoW DMX Classic system, the SHoW DMX Neo system uses SHoW IDs as a quick way to set RF configuration options. Each SHoW ID represents a combination of one of 16 hopping patterns and one of four bandwidth settings. 7400-5707 Vero Transceiver supports Neo and Neo Adaptive SHoW IDs only.

### The Transmitter and Receiver SHoW IDs must match for the units to communicate.

The SHoW DMX Vero Transceiver is preset at the factory with SHoW ID 201 for Adaptive Spread Spectrum Frequency Hopping and Neo Low Latency broadcast mode.

SHoW ID may be set manually using the SHoW ID rotary switches or using RDM. Whichever method is used last takes precedence. The unit maintains the last used setting over power cycles, and checks on power up to see if switches have been changed while the unit was off.

To set the SHoW ID manually, simply set the SHoW ID Rotary Switches to the desired SHoW ID.

In order to use RDM, you will also need an RDM controller or a lighting control console with a built-in RDM controller (see below).

### Neo Mode Operation

In Neo Mode, the SHoW DMX Vero Transceiver uses a new broadcast format that reduces latency to ~ 7mS max and provides further resistance to interference susceptibility or creation. Neo Mode supports Adjustable Broadcast Power, Limited Bandwidth, Limited Burst, and provides 64 new SHoW IDs, providing 16 hopping patterns in each Bandwidth setting.

### Neo SHoW ID Tables

SHoW ID	Mode	Hopping Pattern	Bandwidth
101	Neo	1	Full
102	Neo	2	Full
103	Neo	3	Full
104	Neo	4	Full
105	Neo	5	Full

106	Neo	6	Full
107	Neo	7	Full
108	Neo	8	Full
109	Neo	9	Full
110	Neo	10	Full
111	Neo	11	Full
112	Neo	12	Full
113	Neo	13	Full
114	Neo	14	Full
115	Neo	15	Full
116	Neo	16	Full

SHoW ID	Mode	Hopping Pattern	Bandwidth
117	Neo	1	Limited Low, Wi-Fi 1-6
118	Neo	2	Limited Low, Wi-Fi 1-6
119	Neo	3	Limited Low, Wi-Fi 1-6
120	Neo	4	Limited Low, Wi-Fi 1-6
121	Neo	5	Limited Low, Wi-Fi 1-6
122	Neo	6	Limited Low, Wi-Fi 1-6
123	Neo	7	Limited Low, Wi-Fi 1-6
124	Neo	8	Limited Low, Wi-Fi 1-6
125	Neo	9	Limited Low, Wi-Fi 1-6
126	Neo	10	Limited Low, Wi-Fi 1-6
127	Neo	11	Limited Low, Wi-Fi 1-6
128	Neo	12	Limited Low, Wi-Fi 1-6
129	Neo	13	Limited Low, Wi-Fi 1-6
130	Neo	14	Limited Low, Wi-Fi 1-6
131	Neo	15	Limited Low, Wi-Fi 1-6
132	Neo	16	Limited Low, Wi-Fi 1-6

SHoW ID	Mode	Hopping Pattern	Bandwidth
133	Neo	1	Limited Mid, Wi-Fi 5-9
134	Neo	2	Limited Mid, Wi-Fi 5-9
135	Neo	3	Limited Mid, Wi-Fi 5-9
136	Neo	4	Limited Mid, Wi-Fi 5-9
137	Neo	5	Limited Mid, Wi-Fi 5-9
138	Neo	6	Limited Mid, Wi-Fi 5-9
139	Neo	7	Limited Mid, Wi-Fi 5-9
140	Neo	8	Limited Mid, Wi-Fi 5-9
141	Neo	9	Limited Mid, Wi-Fi 5-9

142	Neo	10	Limited Mid, Wi-Fi 5-9
143	Neo	11	Limited Mid, Wi-Fi 5-9
144	Neo	12	Limited Mid, Wi-Fi 5-9
145	Neo	13	Limited Mid, Wi-Fi 5-9
146	Neo	14	Limited Mid, Wi-Fi 5-9
147	Neo	15	Limited Mid, Wi-Fi 5-9
148	Neo	16	Limited Mid, Wi-Fi 5-9

SHoW ID	Mode	Hopping Pattern	Bandwidth
149	Neo	1	Limited High, Wi-Fi 7-11
150	Neo	2	Limited High, Wi-Fi 7-11
151	Neo	3	Limited High, Wi-Fi 7-11
152	Neo	4	Limited High, Wi-Fi 7-11
153	Neo	5	Limited High, Wi-Fi 7-11
154	Neo	6	Limited High, Wi-Fi 7-11
155	Neo	7	Limited High, Wi-Fi 7-11
156	Neo	8	Limited High, Wi-Fi 7-11
157	Neo	9	Limited High, Wi-Fi 7-11
158	Neo	10	Limited High, Wi-Fi 7-11
159	Neo	11	Limited High, Wi-Fi 7-11
160	Neo	12	Limited High, Wi-Fi 7-11
161	Neo	13	Limited High, Wi-Fi 7-11
162	Neo	14	Limited High, Wi-Fi 7-11
163	Neo	15	Limited High, Wi-Fi 7-11
164	Neo	16	Limited High, Wi-Fi 7-11

### Neo Adaptive Mode Operation

The SHoW DMX Vero Transceiver can be configured to operate in the new Neo Adaptive (AFHSS) Mode. Neo Adaptive Mode uses an Adaptive Spread Spectrum Frequency Hopping broadcast format in which the system detects interference and adapts its frequency hopping channel set automatically to avoid it.

Neo Adaptive Mode supports Adjustable Broadcast Power and provides 4 new Adaptive Mode SHoW IDs. Latency is also reduced to ~7mS max in Adaptive Mode.

### Neo Adaptive SHoW ID Table

SHoW ID	Mode	Hopping Pattern	Bandwidth
201	Neo Adaptive	Adaptive	Full
202	Neo Adaptive	Adaptive	Full
203	Neo Adaptive	Adaptive	Full
204	Neo Adaptive	Adaptive	Full



### Adjustable Output Power

The broadcast power of the SHoW DMX Vero Transceiver is adjustable to allow the user to calibrate the system's broadcast power to match the requirements of the application.

### Limited Bandwidth Hopping

In the Limited Bandwidth Hopping mode, the SHoW DMX Vero Transceiver system is assigned to one of three sub-bands of the full 2.4Ghz spectrum. Each sub-band occupies approximately 2/5s of the full band, with one sub-band positioned at the low end, one in the center, and one at the high end of the full spectrum. The three sub-bands overlap and each avoids some combination of WiFi channels. This will allow the SHoW DMX Vero Transceiver to be set to broadcast in a different area of the spectrum than other equipment being used in the area, to minimize or eliminate interference with WiFi or other channel specific or limited bandwidth equipment.

### Limited Burst DMX Output

Limited Burst mode reduces the number of DMX channels and the amount of radio energy that is broadcast by the Transmitter.

If you don't need all 512 DMX values and you need to control the radio energy in your system as much as possible, then you can use Limited Burst to target only the DMX channels you need, and reduce your radio footprint even further.

In Limited Burst mode, the user may select a contiguous group of 51 slots or more DMX slots in multiples of 52 slots (51+52, 51+104, etc.). Limited Burst slot counts include: 51, 103, 155, 207, 259, 311, 363, 415, and 467. These may be assigned to any starting address that will not exceed the total 512 slot count when added to the remaining slots in the selected Burst size (e.g. with 467 slots, the highest allowed starting address is 46, as 46+466 = 512).

### RDM Operation

RDM stands for Remote Device Management. RDM is a lighting control protocol enhancement to DMX512 specified by PLASA (formerly ESTA); the official name is *ANSI/ESTA E1.20, Entertainment Technology - Remote Device Management over USITT DMX512*.

Using RDM, you can select one of the 68 available Neo SHoW IDs, adjust the broadcast power, configure for limited burst transmission, edit the RDM Device Label, and enable or disable RDM traffic.

The SHoW DMX Vero Transceiver is fully enabled as an RDM proxy system, so you can use RDM to manage your SHoW DMX Vero Transceiver system and any connected RDM responders that are downstream of the system.

Remember that when RDM is enabled, the system uses ~ 25% of its available DMX bandwidth for RDM so DMX fidelity and refresh rate are reduced. For best DMX fidelity, disable RDM traffic from the Receivers back to the Transmitting unit when you are not using RDM.

You can use RDM to change SHoW IDs in connected devices. Remember that once you have changed the SHoW ID in a connected Receiver, you will lose communication with that Receiver until you change your Transmitter to the matching SHoW ID.

The SHoW DMX Vero Transceiver supports the following RDM PIDs:

Get	Set	Reduce	RDM Parameter	PID	Comment
-----	-----	--------	---------------	-----	---------

Allowed	Allowed	d RDM			
		X	DISC_UNIQUE_BRANCH	0x0001	
		X	DISC_MUTE	0x0002	
		X	DISC_UN_MUTE	0x0003	
X		X	PROXIED_DEVICES	0x0010	
X		X	PROXIED_DEVICE_COUNT	0x0011	
X		X	QUEUED_MESSAGE	0x0020	
X		X	SUPPORTED_PARAMETERS	0x0050	
X		X	PARAMETER_DESCRIPTION	0x0051	
X		X	DEVICE_INFO	0x0060	Reports Category 0x0801
X		X	PRODUCT_DETAIL_ID_LIST	0x0070	Repots ID 0x0604
X		X	DEVICE_MODEL_DESCRIPTION	0x0080	
X		X	MANUFACTURE_LABEL	0x0081	City Theatrical, Inc.
X	X	X	DEVICE_LABEL	0x0082	
X	X	X	FACTORY_DEFAULTS	0x0090	
X		X	SOFTWARE_VERSION_LABEL	0x00C0	Reports CE/FCC
X	X		DMX_PERSONALITY	0x00E0	Sets Limited Burst
X			DMX_PERSONALITY_DESCRIPTION	0x00E1	
X	X		DMX_START_ADDRESS	0x00F0	
X		X	SENSOR_DEFINITION	0x0200	RSSI, Temp
X		X	SENSOR_VALUE	0x0201	
X	X	X	IDENTIFY_DEVICE	0x1000	
X	X	X	RDM_TRAFFIC_ENABLE	0x7FE2	Draft
X	X		SHOW_ID	0x8000	
X	X		OUTPUT_POWER	0x8001	
X	X		HOP_PATTERN	0x8002	
X	X		BANDWIDTH	0x8003	
X	X		LATENCY	0x8019	
X	X	X	DMX_RDM_INTERLEAVE_RATIO	0x801B	
X	X	X	PROXIED_DEVICES_ENHANCED	0x801C	
X	X		ADAPTIVE_ON_OFF	0x801D	

In order to allow RDM traffic and discovery and control of connected Responders you must enable RDM Traffic (Set RDM\_TRAFFIC\_ENABLE to 01).

Note that DMX transmission fidelity may be slightly reduced when RDM Traffic is enabled.

To learn more about RDM, a good place to start is the Wikipedia article on RDM (lighting) at: [http://en.wikipedia.org/wiki/RDM\\_\(lighting\)](http://en.wikipedia.org/wiki/RDM_(lighting))

**Optional or Custom Antenna Accessories**

You system may have been supplied with optional or custom antenna distribution accessories such as antennas, splitters, attenuators, lightning arrestors, or other devices. Please contact City Theatrical directly for details.